

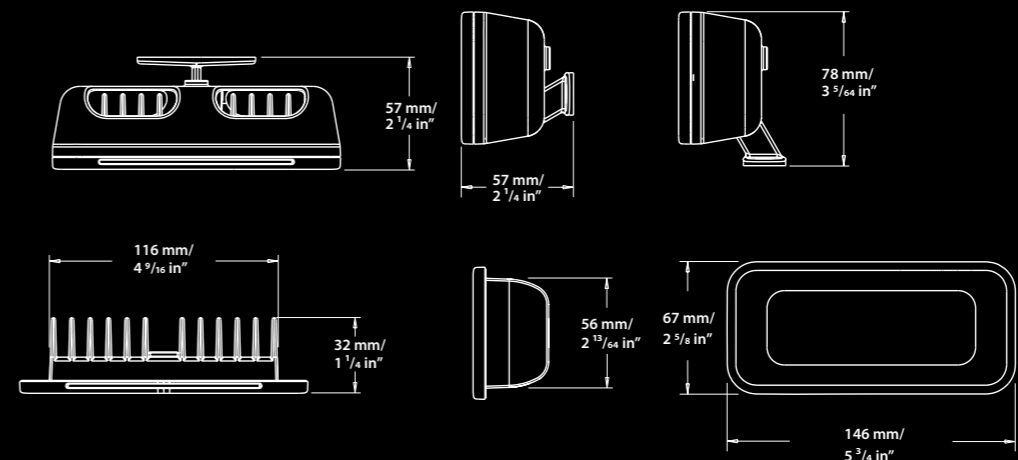

# Spreader Light 12

The new SL12 comes in two versions; Flush Mount and Bracket Mount allowing functionality and smooth styling for a wide range of applications.

New for 2013 is the very powerful SL12. This unit has built in thermo control to monitor heat and will automatically ramp itself down if left on during excessively hot days. The SL12 is available in flush or bracket mount versions. Both versions of the light are easy to install, offering a fantastic output and a neat appearance. Manufactured in marine grade aluminium and powder coated with a stainless steel or white bezel.



## Technical Specifications

- Cable length 2 metres (6 feet)
- Current draw less than 2 amps @ 12 volt dc
- Reverse polarity protected
- Available in flush or bracket mount
- Available in 8000k White
- Long life, high output 12 LED light engine
- White or S/S bezel
- Can accept 12 or 24 volt dc
- Recommended for any vessel where quality deck lighting is essential
- Powder coated aluminium housing with scratch resistant polymer lens
- Very wide beam to illuminate large areas
- 2 year warranty



## Brilliant White

- Color temperature 8000 degrees Kelvin
- Fixture Lumens : 2000 lm